

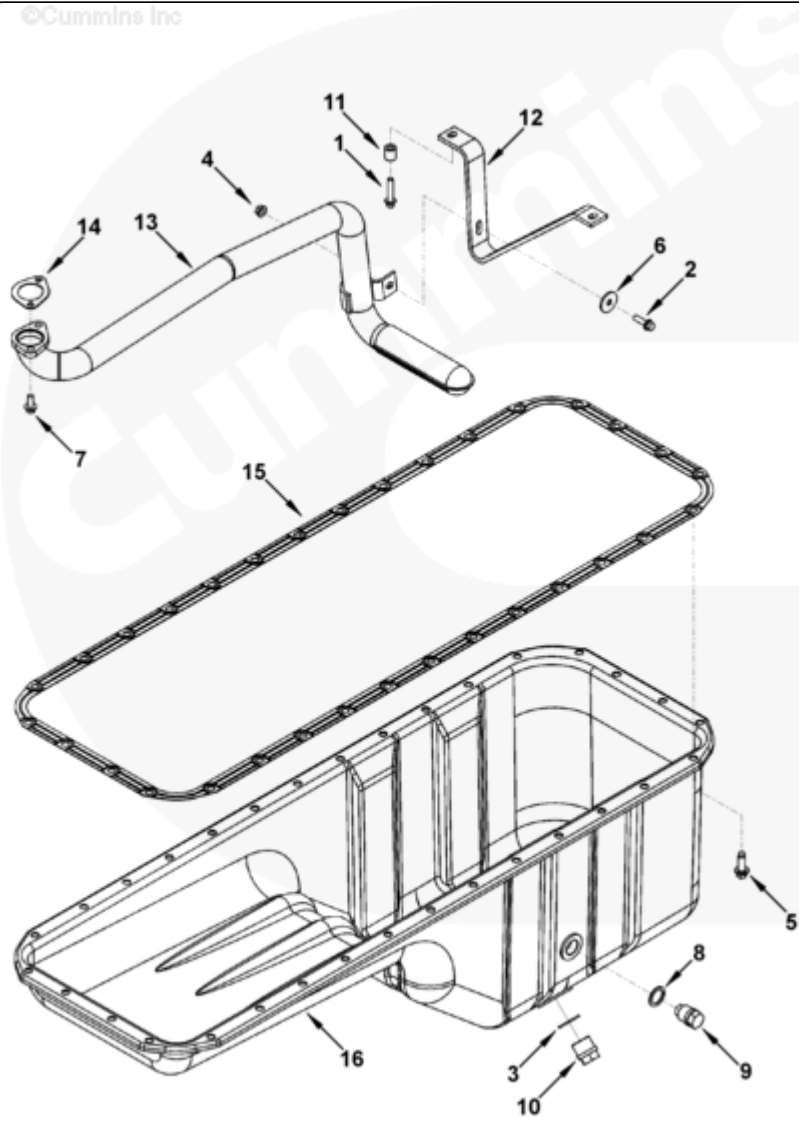

Parts Catalog - Option Detail

Electronic Parts Catalog - Option Detail				
Option	Group	Graphic	Film Card	Date
OP9012-07	07.01	op958gi	Z	22-SEP-03
Engines	6C8.3, C GAS PLUS CM556, G8.3, G8.3 CM558, GTA8.3 CM558, ISC CM2150, ISC CM554, ISC CM850, ISC8.3 CM2250, ISC8.3 G CM2180 C101, ISL CM2150, ISL CM554, ISL CM850, ISL G CM2180, ISL8.9 CM2150 L110, ISL8.9 CM2880 L112, ISL9 CM2150 SN, ISL9 CM2250, ISL9 CM2350 L101, ISL9 CM2350 L111, ISLE4 CM850, L GAS PLUS CM556, L8.9, L8.9 L121, L8.9G CMOH2.0 L125B, L9 CM2350 L116B, L9 CM2350 L119B, L9 CM2350 L120C, L9 CM2350 L123B, L9.3 L105, L9.5 L117, L9N CM2380 L124B, QSC8.3 CM2250, QSC8.3 CM2880 C102, QSC8.3 CM554, QSC8.3 CM850(CM2850), QSL9 CM2250, QSL9 CM2250 L115, QSL9 CM2350 L102, QSL9 CM2350 L107, QSL9 CM2350 L118, QSL9 CM2350 L122, QSL9 CM554, QSL9 CM850(CM2850), QSL9 G CM558, QSL9 M CM2250 L106, QSL9.3 CM2880 L113			



op958gi

SMALL | MEDIUM | LARGE

Cart	Ref No	Part Number	Part Description	Required	Remarks
View My Cart					
		OP9012-07	Oil Pan		Oil Pan...(More)
					Family: C Series
					Cylinders: 6
					Sump Style: Standard
					Sump Location: Rear
					Oil Pan Material: Stamped
					Steel
					Drain Location: Fuel Pump
					Side
					Pan High Capacity (qt): 20
					(18.921 L)
					Pan Low Capacity (qt): 16
					(15.137 L)
					Front Up Angularity (deg):
					45
					Front Down Angularity (deg):
					45
					Pan Side to Side Angularity
					(deg): 45
					Oil Pan Type: Non-Isolated
					Internally Cast Suction
					Tube: No
					Required Oil Filter Medium:
					Cellulose
					Oil Heater Thread Provision:
					No
					Oil Level Sensor Provision:
					No

					Doweled For Flywheel Housing:
					No
					Engine Design Phase: Current
					Product
					Pan Includes Full Perimeter
					Clamping Plates
					Heater Boss Size & Location:
					22mm Fuel Pump
					Washer 3910960 Must Be
					Assembled Between Fastener
					Bearing Surface and Brace
					3927611
					DEP May Use 3282266 Plug in
					Place of 3924148 Plug
<input type="checkbox"/>	1	3900628	Hexagon Flange Head Cap Screw	2	M6 X 1.00 X 30.
<input type="checkbox"/>	2	3901865	Hexagon Flange Head Cap Screw	1	M6 X 1.00 X 20.
<input type="checkbox"/>	3	3902425	Sealing Washer	1	M22
<input type="checkbox"/>	4	3906216	Hexagon Flange Nut	1	M6 X 1.00.
<input type="checkbox"/>	5	3907860	Hexagon Flange Head Cap Screw	32	M8 x 1.25 x 25
<input type="checkbox"/>	6	3910960	Plain Washer	1	M6
<input type="checkbox"/>	7	3913638	Hexagon Flange Head Cap Screw	2	M6 X 1.00 X 16.
<input type="checkbox"/>	8	3920773	Sealing Washer	1	M18
<input type="checkbox"/>	9	3924147	Threaded Plug	1	M18 x 1.50 x 12
<input type="checkbox"/>	10	3924148	Threaded Plug	1	M22 x 1.50 x 14
<input type="checkbox"/>	11	3926865	Mounting Spacer	2	
<input type="checkbox"/>	12	3927611	Tube Brace		
<input type="checkbox"/>	13	3928828	Oil Suction Connection	1	
<input type="checkbox"/>	14	3939352	Oil Suction Connection Gasket	1	

	15	3973509	Oil Pan Gasket	1	
<input type="checkbox"/>	16	3974292	Oil Pan	1	

© 2019 Cummins Inc., Box 3005, Columbus, IN 47202-3005 U.S.A.
Terms of Use and Disclaimers | Recommended System Requirements
Need Assistance? Please click on the Contact Us button in the top right corner of any page.